

- Bubble-tight shut off
- ISA S75.03 Face-to-Face dimensions
- Compact globe valve version
- Stainless steel 316L valve body
- Available with flow direction below and above seat
- 3 and 4" tube weld ends available

Type 2012 can be combined with...

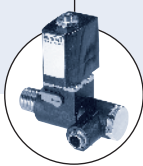

**Type 6012/6014 P**  
Pilot valve

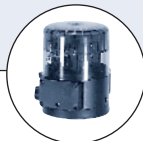

**Type 8631**  
TopControl On/Off

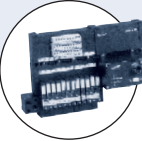

**Type 8640/8644**  
Valve bank

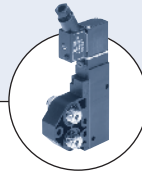

**Type 5470**  
Solenoid valve

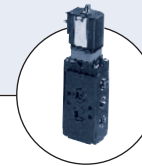

**Type 6519 NAMUR**  
Hi flow pilot valve

The externally piloted globe valve consists of a pneumatically operated piston actuator and a 2/2-way valve body. The actuator is made of PA or, for special operating conditions, PPS. The reliable self-adjusting packing gland provides high sealing integrity. These maintenance-free and robust valves can be fitted with a comprehensive range of accessories for position indication, stroke limitation or manual override.

**1)Note:** Use PPS actuators in the sizes 40, 50 and 63, when the combination of max. media temperature and max. ambient temperature is above the lines shown in the following chart:

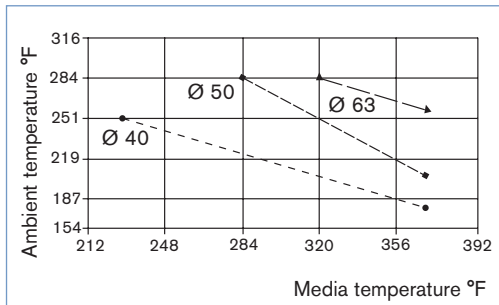

Technical data	
<b>Orifice</b>	1/2" – 4" (DN15–100)
<b>Body material</b>	investment cast 316L
<b>Actuator material</b>	PA, PPS
<b>Plug seal material</b>	PTFE (NBR, FKM and EPDM on request)
<b>Media</b>	Water, alcohol, oils, fuel, salt solution, alkali solutions, organic solvents, steam
<b>Viscosity</b>	Max. 600 mm <sup>2</sup> /s; .93 in <sup>2</sup> /s; 600 cSt
<b>Packing gland</b>	PTFE (with silicone grease)
<b>Media temperature <sup>1)</sup></b>	14°F to 365°F (-10°C to 185°C) with PTFE seal
<b>Ambient temperature</b>	
<b>PA actuator <sup>1)</sup></b>	
Actuator sizes up to Ø 125	14°F to 140°F (-10°C to 60°C)
Actuator sizes Ø 175-225	14°F to 122°F (-10°C to 50°C)
<b>PPS actuator</b>	
Actuator sizes Ø 40-80	41°F to 284°F (5°C to 140°C)
Actuator sizes Ø 100-125	41°F to 194°F (5°C to 90°C)
<b>Installation</b>	As required, preferably with actuator in upright position
<b>Control medium</b>	Neutral gases, air
<b>Max. pilot pressure</b>	
Actuator size Ø 40 – 80	PA and PPS 145 PSI
Actuator size Ø 100	PA 145 PSI
Actuator size Ø 100	PPS 100 PSI
Actuator size Ø 125	PA and PPS 100 PSI
Actuator size Ø 175 – 225	PA 87 PSI

**Materials**

**Actuator size 40-125mm**

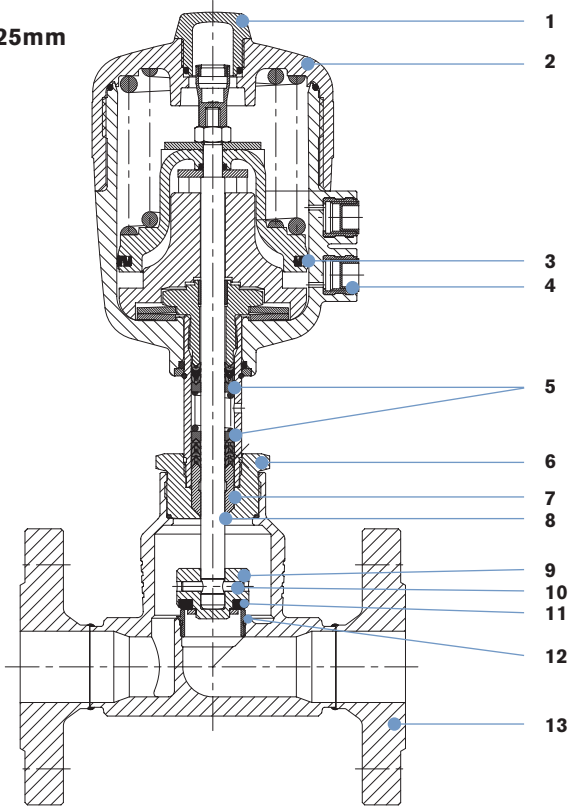

- |    |                 |                        |
|----|-----------------|------------------------|
| 1  | Transparent cap | PC/PSU                 |
| 2  | Actuator        | PA/PPS                 |
| 3  | Cylinder seal   | NBR/FKM                |
| 4  | Pilot air ports | Stainless Steel 303    |
| 5  | V-seals         | PTFE, FKM              |
| 6  | Nipple          | Stainless Steel 316    |
| 7  | Wiper           | PTFE                   |
| 8  | Spindle         | Stainless Steel 316    |
| 9  | Swivel plate    | Stainless Steel 316    |
| 10 | Pin             | Stainless Steel 316    |
| 11 | Seal            | PTFE                   |
| 12 | Valve seat      | Stainless Steel 316 Ti |
| 13 | Valve body      | Stainless Steel 316L   |

**Actuator size 175 and  
225mm**

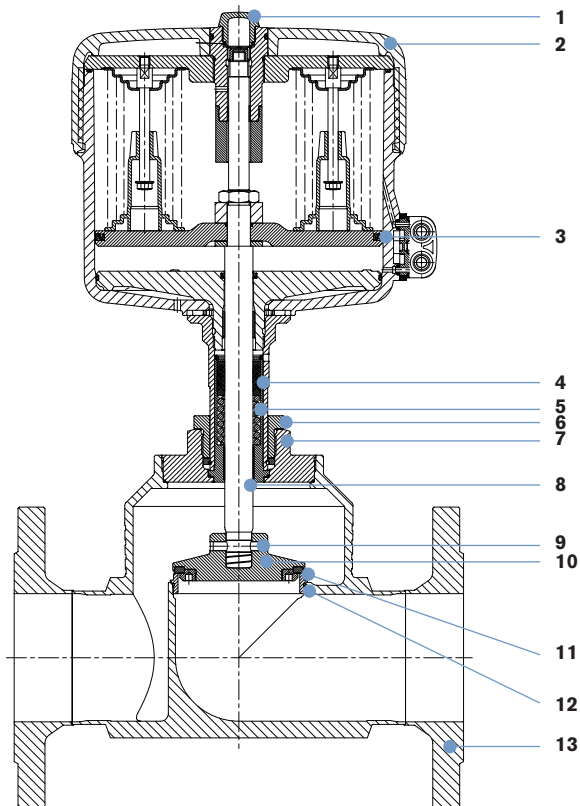

- |    |                 |                        |
|----|-----------------|------------------------|
| 1  | Transparent cap | PC                     |
| 2  | Actuator        | PA                     |
| 3  | Cylinder seal   | NBR                    |
| 4  | V-seals         | PTFE                   |
| 5  | Spring          | Stainless Steel        |
| 6  | Screw           | Stainless Steel 303    |
| 7  | Nipple          | Stainless Steel 316 L  |
| 8  | Spindle         | Stainless steel 316    |
| 9  | Pin             | Stainless Steel 316 L  |
| 10 | Swivel plate    | Stainless Steel 316 L  |
| 11 | Seal            | PTFE                   |
| 12 | Valve seat      | Stainless Steel 316 Ti |
| 13 | Valve body      | Stainless Steel 316L   |

DTS 1000082415 EN Version: A Status: RL (released | freigegeben | validé) printed: 16.07.2008

**Technical data for valves with flow direction below the seat**

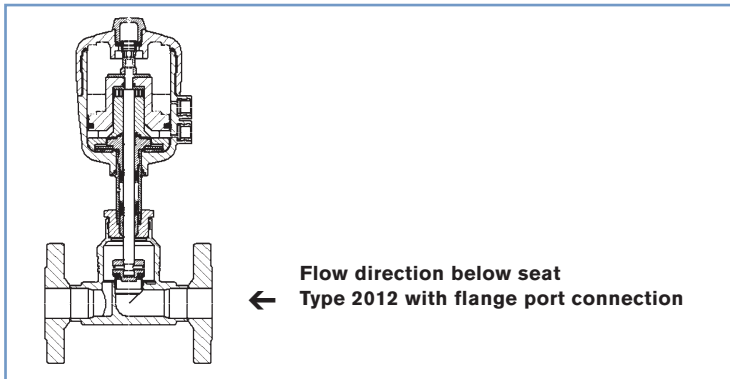

Orifice		Actuator size [mm]	Cv Value	Minimum pilot pressure CFA [PSI]	Maximum operating pressure up to ±365°F		Weight with CFA Flange [lb]
[mm]	[in]				CFA [PSI]	CFB [PSI]	
10	3/8	40	5.50	58	218	232	5
10	3/8	50	5.50	57	232	232	5
15	1/2	40	5.50	58	218	232	5
15	1/2	50	5.50	57	232	232	5
20	3/4	40	9.40	58	95	232	7
20	3/4	50	9.40	57	160	232	7
20	3/4	63	9.40	61	232	-	8
25	1	63	15.1	61	160	232	10
25	1	80	15.1	72	232	-	12
32	1 1/4	63	22.6	61	87	232	15
32	1 1/4	80	22.6	72	218	-	16
40	1 1/2	80	36.0	72	145	232	19
40	1 1/2	125	36.0	47	232	-	31
50	2	100	52.2	50	105	232	30
50	2	125	52.2	47	145	-	34
65	2 1/2	125	84.7	82	174	218	45
65	2 1/2	175	84.7	65	218	-	57
80	3	125	127	81	110	182	54
80	3	175	127	65	145	-	66
80	3	225	127	48	182	-	78
100	4	125	191	82	73	131	73
100	4	175	179	65	102	145	84
100	4	225	179	70	145	-	96

**Pressure charts for control function B and flow direction below the seat**

**3/8" – 3/4"**

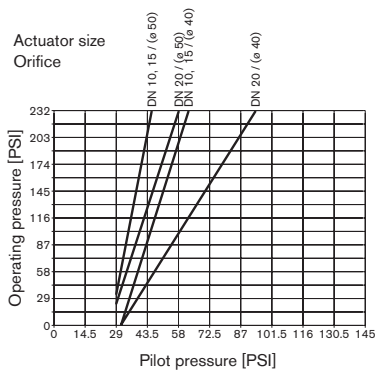

**1" – 2"**

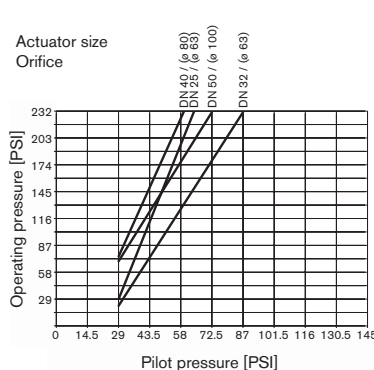

**2 1/2" – 4"**

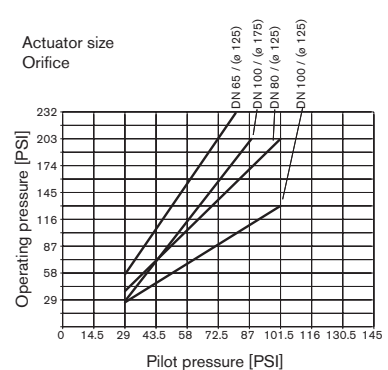

**Ordering chart for valves with flow direction below the seat (other versions on request)**

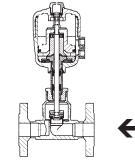

**Valves with flange connection according to ANSI B16.5, flow below seat**

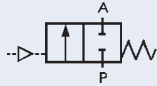
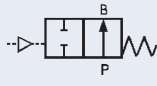
Control function	Orifice	Connection	Actuator size Ø [mm]	Cv value	Minimum pilot pressure [PSI]	Operating pressure up to + 365 °F [PSI]	Item no. PA actuator
 2/2-way valve, NC by spring action	1/2" (15)	Flange	40	5.5	58	218	146 246
			50	5.5	57	232	146 258
	3/4" (20)	Flange	40	9.4	58	95	146 270
			50	9.4	57	160	146 282
	1" (25)	Flange	63	15.1	61	160	146 571
			80	15.1	73	232	146 572
	1 1/2" (40)	Flange	80	36.0	73	145	146 326
			125	36.0	47	232	146 338
	2" (50)	Flange	100	52.2	50	105	146 344
			125	52.2	47	145	146 356
	2 1/2" (65)	Flange	125	84.7	82	174	152 742
			175	84.7	65	218	152 760
	3" (80)	Flange	125	127.6	81	110	155 526
			175	127.6	65	145	152 778
			225	127.6	48	182	152 796
	4" (100)	Flange	125	191.4	81	73	155 545
175			179.8	65	102	152 814	
225			179.8	70	145	152 832	
 2/2-way valve, NO spring action	1/2" (15)	Flange	40	5.5	see chart pg. 3	232	146 252
			50	5.5	see chart pg. 3	232	146 264
	3/4" (20)	Flange	40	9.4	see chart pg. 3	232	146 276
			50	9.4	see chart pg. 3	232	146 288
	1" (25)	Flange	63	15.1	see chart pg. 3	232	146 304
	1 1/2" (40)	Flange	80	36.0	see chart pg. 3	232	146 332
	2" (50)	Flange	100	52.2	see chart pg. 3	232	146 350
	2 1/2" (65)	Flange	125	84.7	see chart pg. 3	218	152 751
	3" (80)	Flange	125	127.6	see chart pg. 3	182	152 769
	4" (100)	Flange	125	191.4	see chart pg. 3	131	152 805
			175	179.8	see chart pg. 3	145	152 823

DTS 1000082415 EN Version: A Status: RL (released | freigegeben | valide) printed: 16.07.2008

**Technical data for valves with flow direction above the seat**

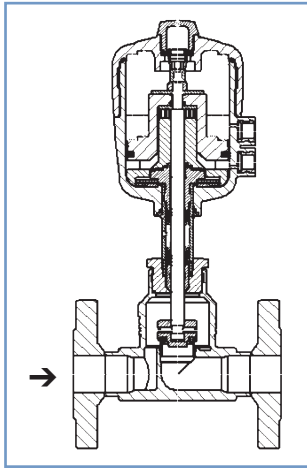

**Flow direction above seat  
Type 2012 with flange connection**

Technical data	Flow direction above the seat
Media	Gaseous media and steam
Other technical data	Please see technical data for flow direction below seat

Orifice	Actuator size [mm]	Cv Value	Minimum pilot pressure [PSI]	Operating pressure upto ±365°F [PSI]	Weight with Flange [lb]
10	3/8"	40	3.5	66	5
10	3/8"	50	3.5	41	5
15	1/2"	40	5.5	64	5
15	1/2"	50	5.5	41	5
20	3/4"	40	9.4	87	7
20	3/4"	50	9.4	54	7
25	1	50	15.1	73	9
32	1 1/4"	63	22.6	66	15
40	1 1/2"	80	36	61	19
50	2"	80	52.2	85	25
65	2 1/2"	125	84.7	82	45
80	3"	125	127.6	82	54
100	4"	125	191.4	82	73

**Pressure charts**

**3/8" – 3/4"**

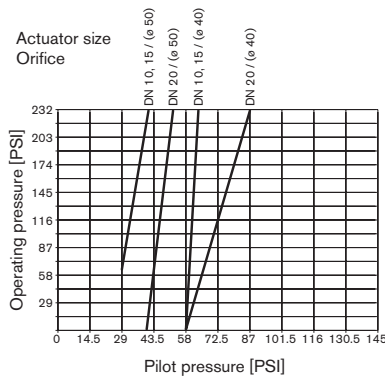

**1" – 2"**

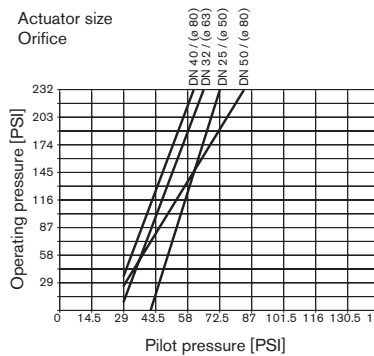

**2 1/2" – 4"**

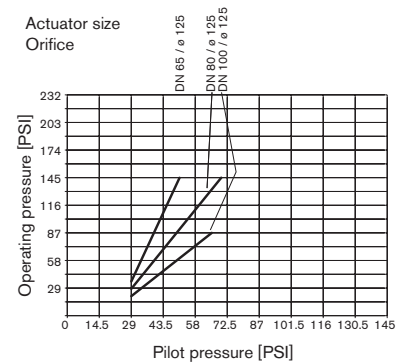

DTS 1000082415 EN Version: A Status: RL (released | freigegeben | validé) printed: 16.07.2008

**Ordering chart for valves** with flow direction above the seat (other versions on request)

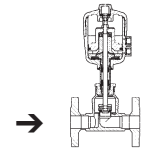

**Valves with flange connection according to ANSI B16.5, flow above seat**

Control function	Orifice	Connection	Actuator size Ø [mm]	C <sub>v</sub> value	Minimum pilot pressure [PSI]	Operating pressure up to + 365°F [PSI]	Item no. PA actuator
	1/2" (15)	Flange	40	5.5	64	232	146 436
			50	5.5	41	232	146 442
	3/4" (20)	Flange	40	9.4	87	232	146 447
			50	9.4	54	232	146 453
	1" (25)	Flange	50	15.1	73	232	146 459
	1 1/2" (40)	Flange	80	36	61	232	146 475
	2" (50)	Flange	80	52.2	85	232	146 486
	2 1/2" (65)	Flange	125	84.7	82	232	152 841
3" (80)	Flange	125	129.6	82	145	152 850	
4" (100)	Flange	125	191.4	82	87	152 859	

**Attention!**

Valves with flow direction above the seat are only conditionally usable for liquid media. Waterhammer may occur!  
For pilot pressures, please refer to Charts on page 5.

Ordering chart for accessories

Pilot valve according to actuator size	Voltage	Item no.
<b>3/2-way pilot valves Type 6012 P/6014 P with banjo mounting; 1/4" NPT</b>		
Type 6012 P for actuator Ø 40 mm	024 V/DC	427 923
	120 VAC/60 Hz	428 551
Type 6012 P for actuator Ø 50 and 63 mm	024 V/DC	428 565
	120 VAC/60 Hz	428 567
Type 6014 P for actuator Ø 80 to 125 mm	024 V/DC	429 134
	120 VAC/60 Hz	429 136
Type 6014 for actuator Ø 175 and 225 mm	024 V/DC	TBA
Type 6014 for actuator Ø 175 and 225 mm	120 VAC/60 Hz	TBA

**Cable plug Type 2506 Form C or Type 2508 Form A**

(other versions, please see datasheets for Types 2506/2508)

Plug configuration acc. DIN EN 175301-803 (previously DIN 43650)	Item no.
Form C, 0 to 250 V w/o circuit (f. Type 6012 P)	008 353
Form A, 0 to 250 V w/o circuit (f. Type 6014 P)	008 376

**Options and accessories (on request)**

- Control function I (double-acting actuator)
- Electrical position feedback, Type 1060, 1062 and 8631
- Magnetic-inductive proximity sensors, Type 1071
- Stroke limitation max. and min./max.
- Manual override (spring close valve only)
- Namur adapter for pilot valves

G x NPT or G x tube adapters			
Fitting type	Shape	Material	Item no.
Male G 1/8 x F 1/8 NPT	Straight	Nickel plated brass	US61425
Male G 1/8 x 1/4" tube	Straight	Nickel plated brass	US61579
Male G 1/8 x 1/4" tube	Swivel elbow	Nickel plated brass	US61440
Male G 1/4 x 1/4" tube	Straight	Nickel plated brass	US63250
Male G 1/4 x 1/4" tube	Swivel elbow	Nickel plated brass	US63251
Male G 1/4 x F 1/4" NPT	Straight	Nickel plated brass	US62754
Male G 1/4 x F 1/4" NPT	Straight	Stainless steel	US-1053

Silencers			
1/8	Straight tube	Polyethylene	CD03892
1/4	Straight tube	Polyethylene	CD01821
G 1/8" Silencer	Straight cone	Sintered bronze	005 305 D
G 1/4" Silencer	Straight cone	Sintered bronze	005 569 D
G 1/4" Silencer	Flat hex	Sintered bronze	780 811 Z

**Note:**

For design reasons, some of the accessories cannot be supplied for actuator sizes Ø 40, Ø 175 and Ø 225 mm. Please request the Accessories data sheet 2000-2031

**Dimensions [inch]**

**1/2" – 4"  
Actuator size  
40–125mm**

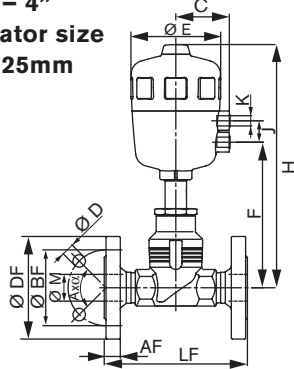

All bodies								ANSI Flange						
DN	Actuator	C	ØE	F	H	K	J	ØDF	LF	ØBF	AF	ØD	Axα	ØM
1/2"	40	1.2	2.1	4.6	6.6	G1/8	0.6	3.5	7.2	2.4	0.4	0.6	4x90°	0.6
1/2"	50	1.7	2.5	5.2	8.3	G1/4	0.9	3.5	7.2	2.4	0.4	0.6	4x90°	0.6
3/4"	40	1.2	2.1	4.6	6.7	G1/8	0.6	3.9	7.2	2.8	0.5	0.6	4x90°	0.8
3/4"	50	1.7	2.5	5.3	8.4	G1/4	0.9	3.9	7.2	2.8	0.5	0.6	4x90°	0.8
3/4"	63	2.0	3.1	6.1	9.7	G1/4	0.9	3.9	7.2	2.8	0.5	0.6	4x90°	0.8
1"	50	1.7	2.5	5.5	8.7	G1/4	0.9	4.3	7.2	3.1	0.6	0.6	4x90°	1.1
1"	63	2.0	3.1	6.3	9.9	G1/4	0.9	4.3	7.2	3.1	0.6	0.6	4x90°	1.1
1"	80	2.3	4	6.5	10.7	G1/4	0.9	4.3	7.2	3.1	0.6	0.6	4x90°	1.1
1 1/2"	63	2.0	3.1	7.2	10.9	G1/4	0.9	5.0	8.7	3.9	0.7	0.6	4x90°	1.6
1 1/2"	80	2.3	4	7.4	11.8	G1/4	0.9	5.0	8.7	3.9	0.7	0.6	4x90°	1.6
1 1/2"	100	2.9	5	8.4	14.4	G1/4	1.9	5.0	8.7	3.9	0.7	0.6	4x90°	1.6
1 1/2"	125	3.4	6.2	8.7	15.6	G1/4	1.9	5.0	8.7	3.9	0.7	0.6	4x90°	1.6
2"	63	2.0	3.1	7.7	11.3	G1/4	0.9	5.6	10	4.8	0.8	0.8	4x90°	2.1
2"	80	2.3	4	7.8	12.2	G1/4	0.9	5.6	10	4.8	0.8	0.8	4x90°	2.1
2"	100	2.9	5	8.6	14.6	G1/4	1.2	5.6	10	4.8	0.8	0.8	4x90°	2.1
2"	125	3.4	6.2	8.9	15.8	G1/4	1.2	5.6	10	4.8	0.8	0.8	4x90°	2.1
2 1/2"	125	3.4	6.2	10	16.9	G1/4	1.2	7.0	10.8	5.5	0.9	0.8	4x90°	2.5
3"	125	3.4	6.2	10.4	17.3	G1/4	1.2	7.5	11.7	6.0	0.9	0.8	4x90°	3.1
4"	125	3.4	6.2	10.8	17.7	G1/4	1.2	9.0	13.8	7.5	0.9	0.8	8x45°	4.1

**2 1/2" – 4"  
Actuator size  
175 and  
225mm**

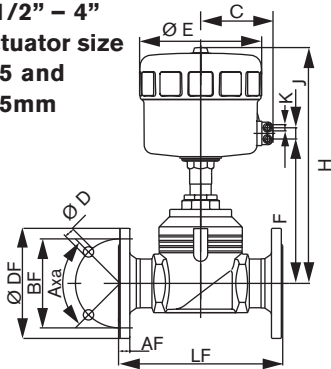

All Actuators							ANSI Flange				
Orifice DN	Actuator size Ø	C	E	F	H	J	DF	LF	BF	AF	ØD
2 1/2"	K-175	5.1	8.3	11.4	19.3	0.9	7.0	10.9	5.5	0.9	0.8
3"	K-175	5.1	8.3	11.7	19.6	0.9	7.5	11.7	6.0	0.9	0.8
3"	L-225	6.1	10.3	11.8	19.5	0.9	7.5	11.7	6.0	0.9	0.8
4"	K-175	5.1	8.3	12.1	20	0.9	9.0	13.9	7.5	0.9	0.6
4"	L-225	6.1	10.3	12.2	19.8	0.9	9.0	13.9	7.5	0.9	0.8

Angles Ax	
Port size	ANSI Flange
2 1/2"	4 x 90°
3"	4 x 90°
4"	4 x 90°

DTS 1000082415 EN Version: A Status: RL (released | freigegeben | valide) printed: 16.07.2008

In case of special application conditions, please consult for advice.

We reserve the right to make technical changes without notice.

0702/3\_US-en\_1000082415