

Insertion Flow sensor for continuous flow measurement

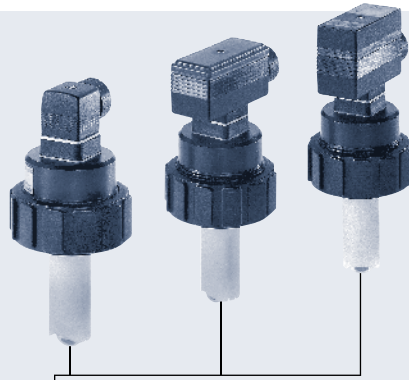

Type 8020 can be combined with...

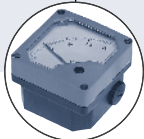

Type 8034

Flow indicator
Wall or Panel

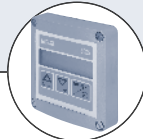

Type 8025

Flow transmitter
Wall or Panel



Type 8023

4–20 mA
output module

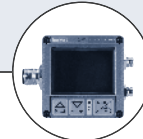

Typ 8623-2

PI Flow–
Controller



Type 2712 (8630)

Continuous
TopControl System



PLC

- Economic integration into pipe systems
- 2-wire frequency coil (sinusoidal) version
3-wire frequency Hall effect (pulse) version
to directly interface with PLC's (both PNP
and NPN)
- Can be upgraded to a low cost transmitter
providing a calibrated pulse or 4–20 mA
- Connection to Burkert devices in remote
versions

The paddle-wheel flow sensor for continuous flow measurement is especially designed for use in neutral, slightly aggressive, solid free liquids. The Burkert designed fitting system ensures simple installation of the sensors into all pipes from 1/2" to 16".

The sensor produces frequency signal (coil or Hall effect), proportional to the flow rate, which can easily be transmitted and processed by:

- a Burkert remote transmitter/indicator (Type 8025/8034/8032 remote versions)

- a transmitter module 8023 into a 4–20 mA output signal
- a pulse divider module 8021 into adjustable frequency output signal
- a batch controller 8600 mounted on a valve

General data	
Compatibility	with all fittings S020 (see corresp. datasheet)
Materials	
Sensor housing	PVDF
Housing	PE
Union nut	PC
Cable plug	PA, brass electro-silver-plated
Materials wetted parts	
Paddle-wheel	PVDF
Axis and bearing	Ceramic
Seal	FKM/EPDM
Electrical connections	Cable plug EN 175301–803
Voltage supply cable	
Cross-section	1.5 mm ² max.
Recommended length	max. 33 ft, shielded (coil sensor) max. 165 ft, shielded (hall sensor)

Complete device data (fitting + electronic module)	
Pipe diameter	1/2" to 16" (DN 15 to 400)
Measuring range	
Hall	1.0 ft/s to 32.8 ft/s (0.3 m/s to 10 m/s)
Coil	1.6 ft/s to 32.8 ft/s (0.5 m/s to 10 m/s)
Medium temperature max.	122°F (50°C) with PVC fitting 176°F (80°C) with PP fitting 212°F (100°C) with St.St., brass or PVDF fitting
Fluid pressure max.	145 PSI
Viscosity	300 cSt. max.
Accuracy	
Teach-In	≤ ±0.5% of F.S.* (at 32.8 ft/s)
Standard K-factor	≤ ±(0.5% of F.S. + 2.5% of Reading)*
Linearity	≤ ±0.5% of F.S.* (at 32.8 ft/s)
Repeatability	0.4% of Reading*

Electrical data	
Power supply	
Coil version	None
Hall version	12–30 VDC
Hall "low power" version	12–30 VDC (via Burkert transmitter)
Current consumption	
with sensor	
Hall version	< 50 mA
Hall "low power" version	< 0.8 mA
Output: Frequency	
Coil version	Alternating 0–10V, frequency: 0–300 Hz, Transistor NPN/PNP, open collector, max. 100 mA, frequency: 0–300 Hz
Hall version	Transistor NPN, open collector, Frequency: 0–300 Hz
Hall "low power" version	Frequency: 0–300 Hz
Reversed polarity of DC	Protected

Environment	
Ambient temperature	
operating and storage	32°F up to 140°F (0°C up to +60°C)
Relative humidity	≤ 80%, non condensated

Standards and approvals	
Protection class	IP65
EMC	EN 50081–1, 50082–2

* Under reference conditions i.e. measuring fluid=water, ambient and water temperature=68°F, applying the minimum inlet and outlet pipe straights, matched inside pipe dimensions.
F.S.=Full scale (10 m/s)

Installation

The flow sensor consists of a transducer and an open-cell inline rotor.

When immersed in the flow, the rotating inline rotor produces a frequency modulated measuring signal proportional to the flow.

In a 2- or 3-wire system, the signal can be displayed or processed directly. The output signal is provided via a 4-pole cable plug per DIN 43650.

In the versions with 4-20 mA/adjustable frequency output, an additional NEMA 4 (IP65) housing is plugged on the sensor instead of the cable plug. The output signals are available on a terminal strip inside the enclosure via a PG 9 cable gland.

All parts in contact with fluid are in PVDF or ceramic, enabling use in aggressive fluids.

Installation

The recommended In- and Outflow straight pipe length should permit 10xD in and 3xD out.

According to pipe's design, necessary distances can be larger or use a flow conditioner to obtain the best accuracy. For more information, please refer to EN ISO 5167-1.

The flow sensor can be installed in either horizontal or vertical pipes.

The suitable pipe size is selected using the diagram on the next page. Pressure and temperature ratings must be followed according to the selected fitting material (see next page).

The flow sensor is not designed for gas flow measurement.

Principle of Operation



When liquid flows through the pipe, the inline rotor is set in rotation producing a measuring signal in the transducer (coil or Hall Sensor). The induced voltage is AC. The frequency and amplitude are proportional to the flow.

The version 8020 "low power" flow sensor can only be operated with a flow transmitter 8025 in panel or wall-mount version. It can measure flow from 1.0 ft/s (0.3 m/s) flow velocity.

The flow sensor 8020 with coil requires no external power supply and measures flow from 1.6 ft/s (0.5 m/s) flow velocity. This flow sensor can also be operated with a flow transmitter 8025 in panel or wall-mount version.

The flow sensor 8020 with Hall Sensor requires an external power supply of 12-30 VDC and measures flow from 1.0 ft/s (0.3 m/s) flow velocity.

The flow transmitter 8020 with 4-20 mA output requires an external power supply of 12-24 VDC and measures flow from 1.0 ft/s (0.3 m/s) flow velocity.

The flow sensor 8020 with adjustable frequency output requires an external power supply of 12-30 VDC and measures flow from 1.0 ft/s (0.3 m/s) flow velocity.

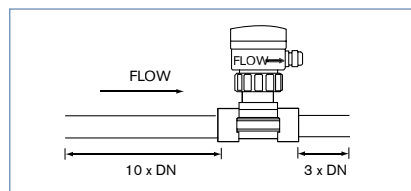
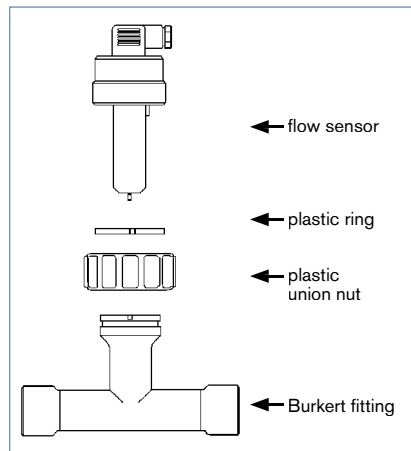

Examples of fitting selection

The suitable pipe size is selected using the diagram below.

Example 1:
 Specification of nominal flow: 50 gpm
 Ideal flow velocity: 8 fps
 For these specifications, the diagram indicates a pipe size of 1-1/2".

Example 2:
 Specification of nominal flow: 10 m³/h
 Ideal flow velocity: 2-3 m/s
 For these specifications, the diagram indicates a pipe size of DN 40.

Pressure – temperature diagram for plastics

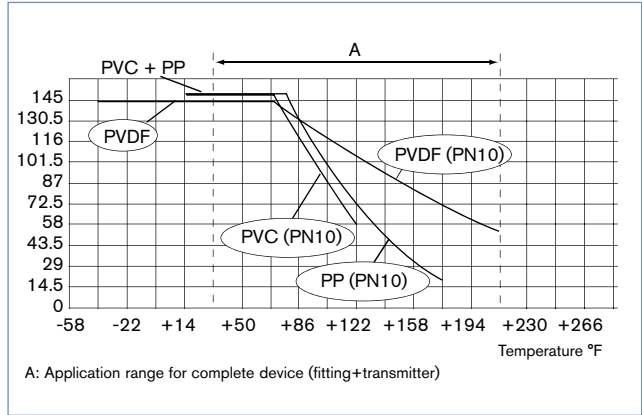

DTS 1000082462 EN Version: - Status: RL (released | freigegeben | valide) printed: 13.08.2008

Flow sensor 8020 diagram (gpm, DN in inch and fps)

Example 1:

- Specification of nominal flow: 10 m³/h
- Ideal flow velocity: 2...3m/s
- For these specifications, the diagram indicates a pipe size of DN 40

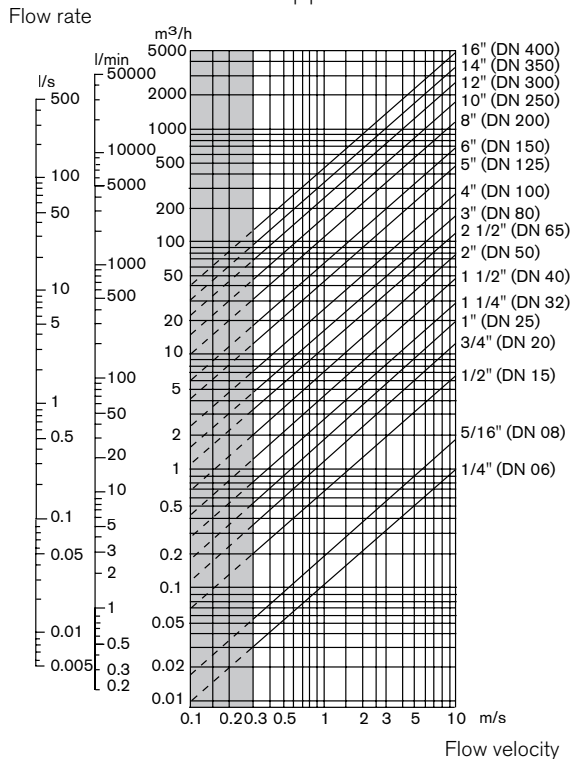

Example 2:

- Specification of nominal flow: 50 gpm
- Ideal flow velocity: 8 fps
- For these specifications, the diagram indicates a pipe size of 1 1/2"

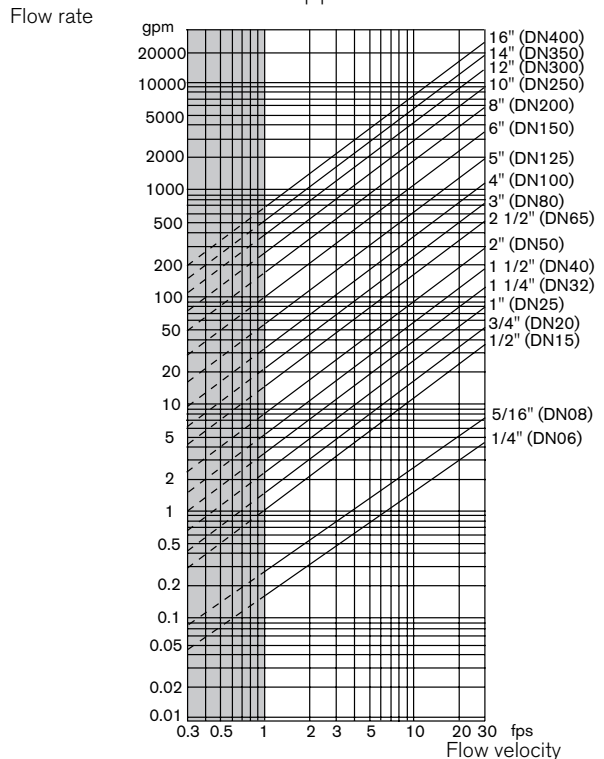

Technical data

General Data

Pipe diameter	From 1/2" (for more detailed information, please see chapter fittings)
Measuring range	1.0 fps to 32.8 fps (0.3 m/s to 10 m/s) From 0.9 gpm (1/2" pipe, 1.0 fps flow velocity) From 3 l/min (DN 15 pipe 0.3 m/s flow velocity)
Measuring error	1. With individual works calibration (on request): ≤ ±0.5% o.F.S. (at 33 fps)* 2. With standard mean K-factor: ≤ ± (0.5% o.F.S. + 2.5% o.R.)*
Linearity	≤ ±0.5% o.F.S. (at 33 fps)*
Repeatability	0.4% o.R.*
Pressure class plastic and metal fitting	84 PSI, PN 6
Ambient temperature	32°F to 140°F (0°C to 60°C)
Storage temperature	32°F to 140°F (0°C to 60°C)
Enclosure	NEMA 4. (Relative humidity max. 80%)
Pulses/rotation	2
Sensor housing	PVDF
Inline rotor	PVDF
Axis and bearing	Ceramic
Housing	PE
Union nut	PC
O-rings	FKM/EPDM

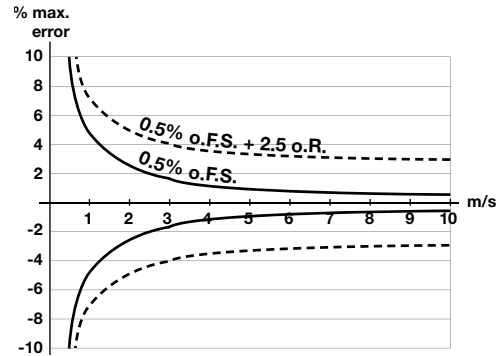

Specific Data for 8020 with Coil

Fluid temperature max.	PVC: 122°F (50°C); PP: 176°F (80°C); PVDF: 212°F (100°C); Stainless steel and brass: 212°F (100°C)
Measuring range	1.6 to 32.8 ft/s (0.5 to 10 m/s)
Supply voltage	none
Output signal	AC: approx. 0–10 V, frequency: 0–300 Hz
Cable length	33 ft. (use shielded cable of max. 1.5mm ² wire cross section)

Specific Data for 8020 with Hall Effect

Fluid temperature max.	PVC: 122°F (50°C); PP: 176°F (80°C); PVDF: 176°F (80°C); Stainless steel and brass: 176°F (80°C)
Measuring range	1.0 to 32.8 ft/s (0.3 to 10 m/s)
Supply voltage	12–30 VDC
Output signal	Transistor PNP, NPN open collector max. 100 mA; frequency: 0–300 Hz
Cable length	165 ft. (use shielded cable of max. 1.5mm ² wire cross section)

Specific Data for 8020 with Hall Effect "Low Power"

Fluid temperature max.	PVC: 122°F (50°C); PP: 176°F (80°C); PVDF: 176°F (80°C); Stainless steel and brass: 176°F (80°C)
Measuring range	1.0 to 32.8 ft/s (0.3 to 10 m/s)
Cable length	165 ft. (use shielded cable of max. 1.5mm ² wire cross section)
(Can only be connected to separate versions of flow transmitter/indicator Type 8025, 8023, 8021, SE34)	

Specific Data for 8020 with 4-20 mA Output (8023)

Associated flow sensor	Coil and Hall low power version
Supply voltage	12–24 VDC
Output signal	4–20 mA
Load	Max. 500Ω at 12 V Max. 1000Ω at 24 V
Accuracy	≤ 2%
Material of additional housing	PA

Specific Data for 8020 with Calibrated Frequency Output (8021)

Associated flow sensor	Hall sensor versions
Supply voltage	12–30 VDC
Output signal	Transistor PNP, NPN open collector max. 100 mA
Accuracy	0.1%
Material of additional housing	PA

* Under reference conditions, i.e. measuring fluid = water, ambient and water temperature = 68°F, applying the minimum inlet and outlet pipe straights, matched inside pipe dimensions
o.R. = of reading
o.F.S. = of full scale (33 fps)

Operation and display

Type 8023, 4-20 mA Output Module

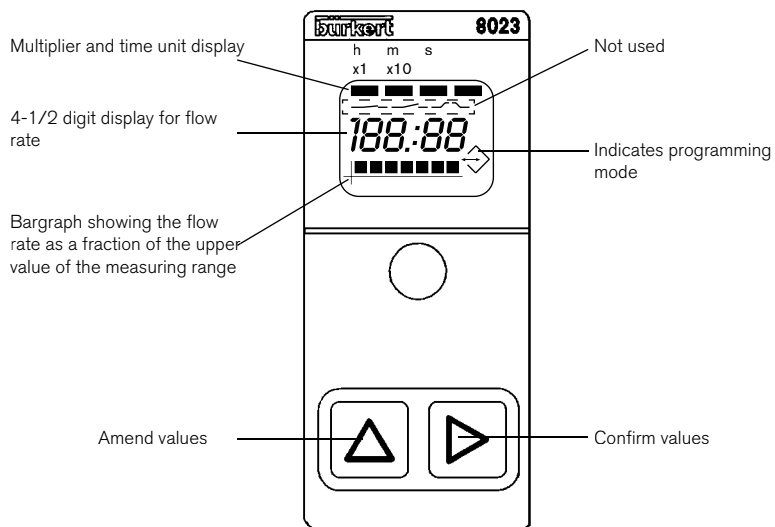

The operation is specified according to two levels:

Indication in operating mode
 – Flow (digits and bargraph)

Parameter definition
 – K-factor
 – Time unit
 – 4-20 mA measuring range

The device works without the control unit. The control unit enables performance by parameter definition.

Type 8021 Adjustable Frequency Output Module

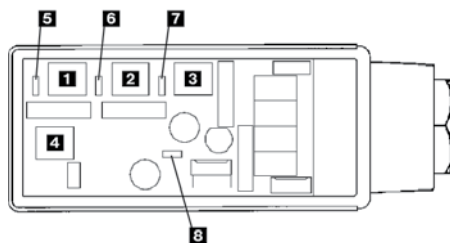

- 1, 2, 3 rotary switches for factor K programming.
- 5, 6, 7 jumpers for decimal position of factor K.
- 4 rotary switch for multiplier D programming.
- 8 reset jumper.

The operation is specified according to the following level:

Parameter definition
 – K-factor
 – Multiplier D

DTS 1000082462 EN Version: - Status: RL (released | freigegeben | validé) printed: 13.08.2008

Dimensions

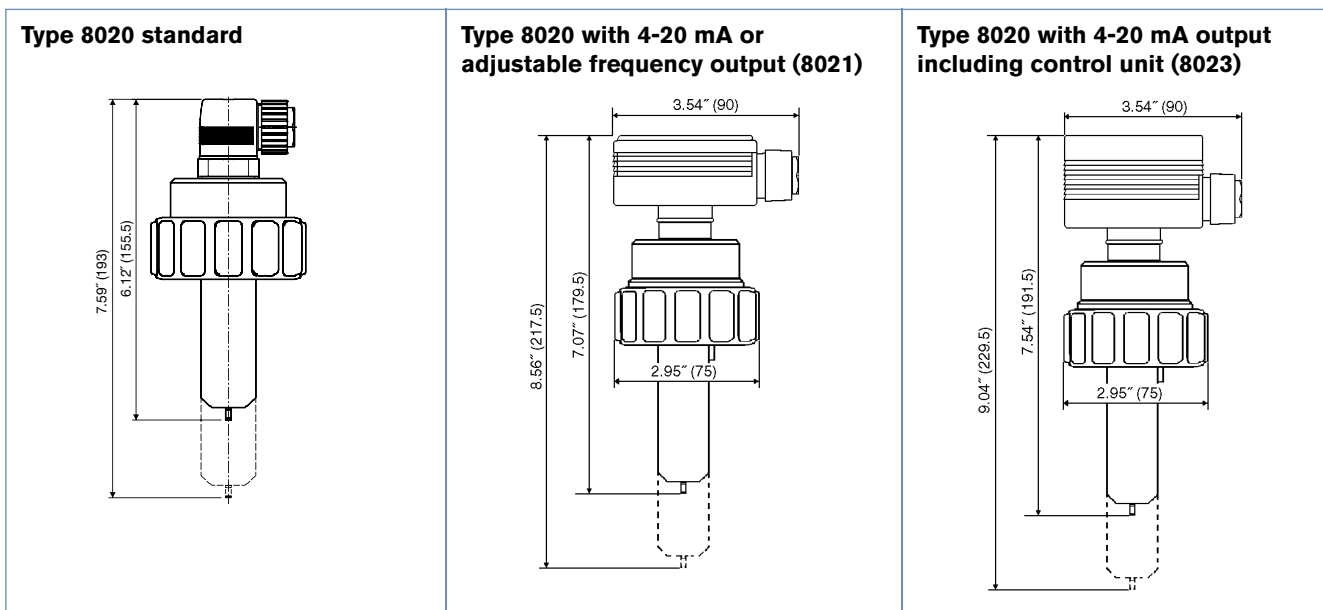

Connection to other Burkert Devices

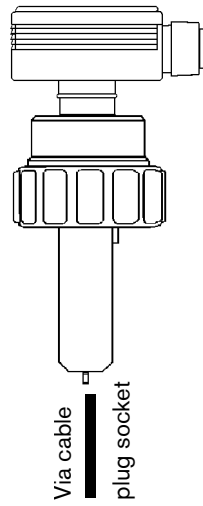

Type 8020 flow sensor with adjustable frequency output open collector NPN or PNP

Type 8020 flow sensor with frequency output:
- from coil
- open collector NPN or PNP

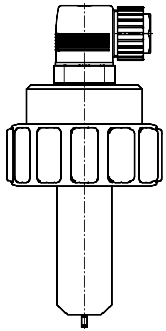

Via cable
plug socket

Type 8020 flow sensor with 4-20 mA current output

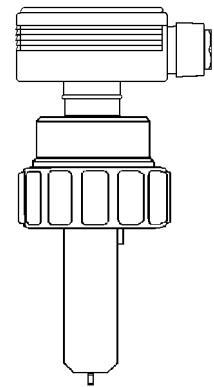

Via cable
plug socket

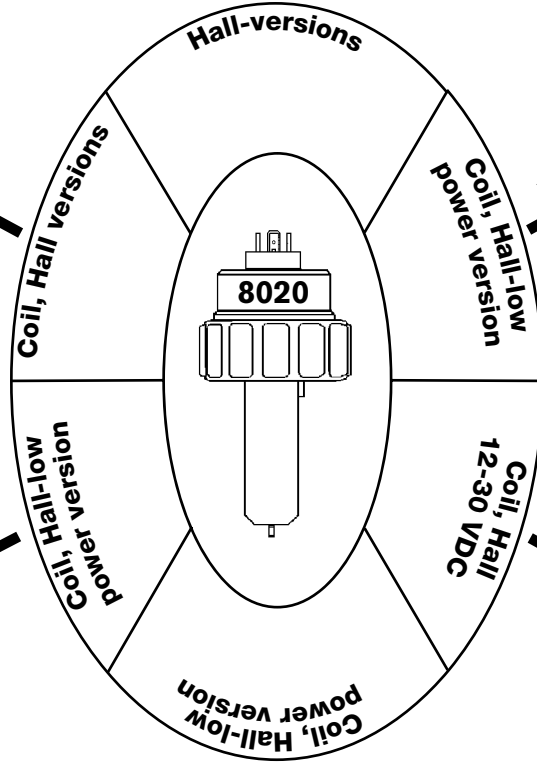

Via cable

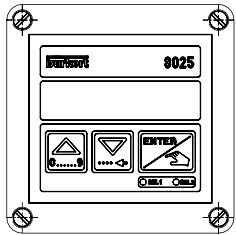

Type 8025 flow transmitter in panel version
(see separate datasheet for more details)

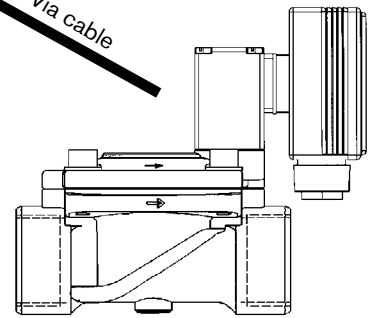

Type 8600 batch controller mounted on valve
(see separate datasheet for more details)

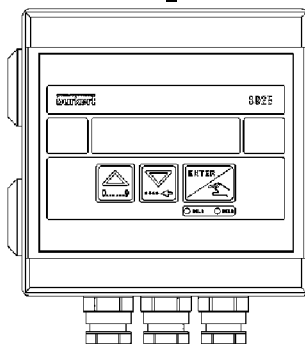

Type 8025 flow transmitter in wall-mount version
(see separate datasheet for more details)

DTS 1000082462 EN Version: - Status: RL (released | freigegeben | validé) printed: 13.08.2008

Ordering data for flow sensor Type 8020

Flow sensor	Power supply	Gasket	Sensor	Cable entry	Item no.
FLOW SENSOR 8020 STANDARD TYPES					
8020 with coil	none	FKM	Coil short	DIN 43650 PG9	419 583 P
8020 with coil	none	FKM	Coil long	DIN 43650 PG9	419 585 R
8020 with Hall sensor	12-30 VDC	FKM	Hall short	DIN 43650 PG9	419 587 K
8020 with Hall sensor	12-30 VDC	FKM	Hall long	DIN 43650 PG9	419 589 V
8020 with Hall sensor, only connectable to 8025/8021/8023/SE34		FKM	Hall short	DIN 43650 PG9	419 591 P
8020 with Hall sensor, only connectable to 8025/8021/8023/SE34		FKM	Hall long	DIN 43650 PG9	419 593 R
FLOW SENSOR 8020 WITH PULSE DIVIDER TYPE 8021					
8020 with Hall sensor and adjustable pulse output NPN & PNP	12-30 VDC	FKM	Hall short	DIN 43650 PG9	419 595 K
8020 with Hall sensor and adjustable pulse output NPN & PNP	12-30 VDC	FKM	Hall long	DIN 43650 PG9	419 597 M
FLOW SENSOR 8020 WITH FLOW TRANSMITTER TYPE 8023					
8020 with coil and adjustable 4-20 mA output	12-24 VDC	FKM	Coil short	DIN 43650 PG9	419 603 B
8020 with coil and adjustable 4-20 mA output	12-24 VDC	FKM	Coil long	DIN 43650 PG9	419 605 D
8020 Hall sensor and adjustable 4-20 mA output	12-24 VDC	FKM	Hall short	DIN 43650 PG9	419 738 H
8020 Hall sensor and adjustable 4-20 mA output	12-24 VDC	FKM	Hall long	DIN 43650 PG9	419 740 P
FLOW TRANSMITTER TYPE 8023 FOR FLOW SENSOR TYPE 8020					
8023 with adjustable 4-20 mA output	12-24 VDC	none	none	1 X PG9	130 428 V
1077-3 control unit for flow transmitter Type 8023	12-24 VDC	none	none	none	130 446 X
PULSE DIVIDER TYPE 8021 FOR FLOW SENSOR TYPE 8020					
8021 with adjustable pulse output	12-30 VDC	none	none	1 X PG9	418 895 P

Insertion fitting dimensions

Internal thread
Stainless steel (316L - 1.4404)
or brass (CuZn39Pb2)

NPT
G
Rc

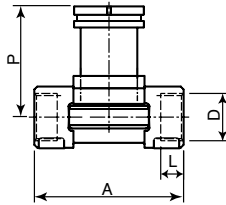

Note: short sensor version

Orifice [DN]	P [mm]	A [mm]	D	L [mm]
1/2" (15)	80.3	85.0	NPT 1/2	17.0
			G 1/2	16.0
			Rc 1/2	15.0
3/4" (20)	77.8	95.0	NPT 3/4	18.3
			G 3/4	17.0
			Rc 3/4	16.3
1" (25)	78.0	105.0	NPT 1	18.0
			G 1	23.5
			Rc 1	18.0
1 1/4" (32)	81.6	120.0	NPT 1 1/4	21.0
			G 1 1/4	23.5
			Rc 1 1/4	21.0
1 1/2" (40)	85.4	130.0	NPT 1 1/2	20.0
			G 1 1/2	23.5
			Rc 1 1/2	19.0
2" (50)	91.5	150.0	NPT 2	24.0
			G 2	27.5
			Rc 2	24.0

External thread
Stainless steel (316L - 1.4404)
or Brass (CuZn39Pb2)
or PVC (only DN 6 and 8)

G

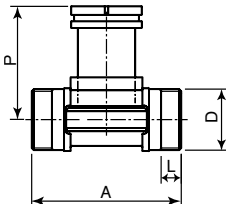

Note: short sensor version

Orifice [DN]	P [mm]	A [mm]	D	L [mm]
1/4" (6)	75.3	90.0	G 1/2	14.0
5/16" (8)	75.3	90.0	G 1/2	14.0
1/2" (15)	80.3	84.0	G 3/4	11.5
3/4" (20)	77.8	94.0	G 1	13.5
1" (25)	78.0	104.0	G 1 1/4	14.0
1 1/4" (32)	81.6	119.0	G 1 1/2	18.0
1 1/2" (40)	85.4	129.0	M 55 x 2	19.0
2" (50)	91.5	149.0	M 64 x 2	20.0

External thread
Stainless steel (316L - 1.4404)

SMS1145

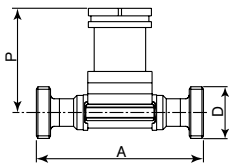

Note: short sensor version

Orifice [DN]	P [mm]	A [mm]	D
1" (25)	77.8	130	Rd40 x 1/6"
1 1/2" (40)	81.6	164	Rd60 x 1/6"
2" (50)	85.4	173	Rd70 x 1/6"

Welding ends
Stainless steel (316L - 1.4404) **BS 4825/ASME BPE**
EN ISO 1127 / ISO 4200
SMS 3008

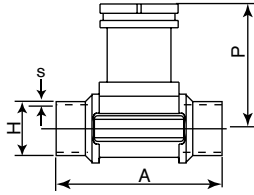

Note: short sensor version

Orifice [DN]	P [mm]	A [mm]	Standard	D [mm]	s [mm]
1/2" (15)	80.3	84.0	ASME BPE	21.30	1.60
	-	-	ISO 4200 -	-	-
	-	-	SMS 3008 -	-	-
3/4" (20)	83.3	84.0	ASME BPE	19.05	1.65
	77.8	94.0	ISO 4200 26.90	1.60	-
	83.3	84.0	SMS 3008 20.00	1.00	-
1" (25)	77.8	94.0	BS4825/ASME BPE	25.40	1.65
	78.0	104.0	ISO 4200 33.70	2.00	-
	77.8	94.0	SMS 3008 25.00	1.20	-
1 1/4" (32)	78.0	104.0	BS4825/ASME BPE	32.00	1.60
	81.6	119.0	ISO 4200 42.40	2.00	-
	78.0	104.0	SMS 3008 -	-	-
1 1/2" (40)	81.6	119.0	BS 4825 38.10	1.65	-
	85.4	129.0	ISO 4200 48.30	2.00	-
	81.6	119.0	SMS 3008 38.00	1.20	-
2" (50)	85.4	128.0	BS4825/ASME BPE	50.80	1.65
	91.5	149.0	ISO 4200 60.30	2.00	-
	85.4	128.0	SMS 3008 51.00	1.20	-
2 1/2" (65)	91.5	147.0	BS4825/ASME BPE	63.50	1.65
	-	-	ISO 4200 -	-	-
	91.5	147.0	SMS 3008 63.50	1.60	-

DTS 1000082462 EN Version: - Status: RL (released | freigegeben | validé) printed: 13.08.2008

Tri-Clamp®
Stainless steel (316L - 1.4404) **BS 4825/ASME BPE***
ISO (for pipe EN ISO 1127 / ISO 4200)
SMS 3017 / ISO 2852*

*Available with internal surface finish Ra=0.8µm

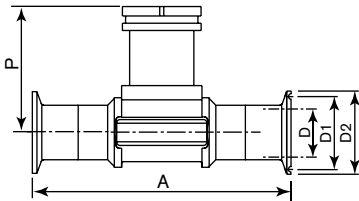

Note: short sensor version

Orifice [DN]	P [mm]	A [mm]	Standard	D2 [mm]	D1 [mm]	D [mm]
1/2" (15)	80.3	130	ASME BPE	-	-	-
	-	-	ISO (for pipe ISO 4200)	18.1	27.5	34.0
	-	-	SMS 3017/ISO 2852	-	-	-
3/4" (20)	77.8	150	ASME BPE	15.75	-	25.0
	80.3	-	ISO (for pipe ISO 4200)	23.7	43.5	50.5
	-	-	SMS 3017/ISO 2852	-	-	-
1" (25)	78.0	160	BS 4825/ASME BPE	22.1	43.5	50.5
	77.8	129.0	ISO (for pipe ISO 4200)	29.7	43.5	50.5
	-	-	SMS 3017/ISO 2852	22.6	43.5	50.5
1 1/4" (32)	81.6	180	BS 4825/ASME BPE	-	-	-
	-	-	ISO (for pipe ISO 4200)	38.4	43.5	50.5
	-	-	SMS 3017/ISO 2852	-	-	-
1 1/2" (40)	85.4	200	BS 4825/ASME BPE	34.8	43.5	50.5
	81.6	161.0	ISO (for pipe ISO 4200)	44.3	56.5	64.0
	-	-	SMS 3017/ISO 2852	35.6	43.5	50.5
2" (50)	91.5	230	BS 4825/ASME BPE	47.5	56.5	64.0
	85.4	192.0	ISO (for pipe ISO 4200)	55.1	70.5	77.5
	-	-	SMS 3017/ISO 2852	48.6	56.5	64.0
2 1/2" (65)	-	-	BS 4825/ASME BPE	60.2	70.5	77.5
	-	-	ISO (for pipe ISO 4200)	-	-	-
	91.5	216.0	SMS 3017/ISO 2852	60.3	70.5	77.5

Insertion fitting dimensions

Flange
Stainless steel (316L - 1.4404)
DIN 2633
ANSI B16-5-1988
JIS 10K

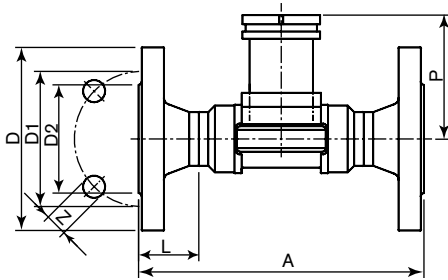

Note: short sensor version

Orifice P	A			NORM	L	Z	D2	D1	D
[DN]	[mm]	DIN/ [mm]	ANSI [mm]						
1/2" (15)	80.3	130.0	152.0	ANSI DIN JIS	23.5	4x15.8 4x14.0 4x15.0	34.9 45.0 51.0	60.3 65.0 70.0	89.0 95.0 95.0
3/4" (20)	77.8	150.0	178.0	ANSI DIN JIS	28.5	4x15.8 4x14.0 4x15.0	42.9 58.0 56.0	69.8 75.0 75.0	99.0 105.0 100.0
1" (25)	78.0	160.0	216.0	ANSI DIN JIS	28.5	4x15.8 4x14.0 4x19.0	50.8 68.0 67.0	79.4 85.0 90.0	108.0 115.0 125.0
1 1/4" (32)	81.6	180.0	229.0	ANSI DIN JIS	31.0	4x15.8 4x18.0 4x19.0	63.5 78.0 76.0	88.9 100.0 100.0	117.0 140.0 135.0
1 1/2" (40)	85.4	200.0	241.0	ANSI DIN JIS	36.0	4x15.8 4x18.0 4x19.0	73.0 88.0 81.0	98.4 110.0 105.0	127.0 150.0 140.0
2" (50)	91.5	230.0	267.0	ANSI DIN JIS	41.0	4x19.0 4x18.0 4x19.0	92.1 102.0 96.0	120.6 125.0 120.0	152.0 165.0 155.0

DTS 1000082462 EN Version: - Status: RL (released | freigegeben | validé) printed: 13.08.2008

True union nut with solvent or fusion spigot
PVC, PP, PVDF

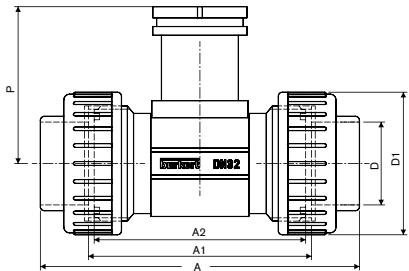

Note: short sensor version

Orifice	P	D1	A			D			A2	A1
[DN]	[mm]	[mm]	DIN	ANSI	JIS	(DIN)	(ANSI)	(JIS)	[mm]	[mm]
1/2" (15)	80.4	43	128	130.0	129	20	21.3	18.40	90	96
1/2" (15)*	81.4	74	148	-	-	20	-	-	110	116
3/4" (20)	77.8	53	144	145.6	145	25	26.7	26.45	100	106
3/4" (20)*	81.4	74	154	-	-	25	-	-	110	116
1" (25)	78.0	60	160	161.4	161	32	33.4	32.55	110	116
1" (25)*	81.4	74	160	-	-	32	-	-	110	116
1 1/4" (32)	81.4	74	168	170.0	169	40	42.2	38.60	110	116
1 1/2" (40)	85.2	83	188	190.2	190	50	48.3	48.70	120	127
2" (50)	91.5	103	212	213.6	213	63	60.3	60.80	130	136

* Analysis version fitting

Solvent or fusion spigot
PP, PVDF

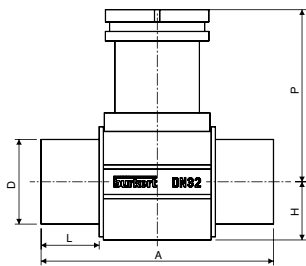

Note: short sensor version

Orifice	P	H	A		D			L	
			PVC	PP/ PVDF	(DIN)	(ANSI)	(JIS)	PVC	PP/ PVDF
[DN]	[mm]	[mm]	[mm]	[mm]	[mm]	[mm]	[mm]	[mm]	[mm]
1/2" (15)	80.4	17.5	90	85	20	21.3	18.40	16.5	14
3/4" (20)	77.8	17.5	100	92	25	26.7	26.45	20.0	16
1" (25)	78.0	21.5	110	95	32	33.4	32.55	23.0	18
1 1/4" (32)	81.4	27.5	110	100	40	42.2	38.60	27.5	20
1 1/2" (40)	85.2	31.5	120	106	50	48.3	48.70	30.0	23
2" (50)	91.5	39.5	130	110	63	60.3	60.80	37.0	27

Welding tab with radius
Stainless steel (316L - 1.4404)

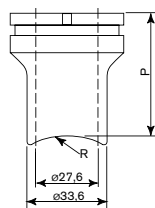

Note:
Sensor version:
 - short for 2" (DN 50) - 8" (DN 200)
 - long for 10" (DN 250) - 14" (DN 350)

Orifice (DN)	P [mm]	R [mm]
2" (50)	56.55	30.15
2 1/2" (65)	54.52	36.65
3" (80)	53.07	44.45
4" (100)	50.71	57.15
5" (125)	48.24	70.65
6" (150)	45.73	84.15
8" (200)	41.01	109.55
10" (250)	73.64	136.55
12" (300)	67.83	161.95
14" (350)	63.94	177.80

Insertion fitting dimensions

Fusion spigot
PE, PP, PVDF

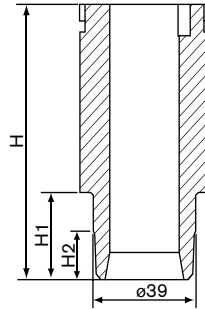

Note:
Sensor version:
- short for 2 1/2" (DN 65) – 4" (DN 100)
- long for 6" (DN 150) – 16" (DN 400)

DIA. [DN]	H [mm]	PE		PP		PVDF	
		H1 [mm]	H2 [mm]	H1 [mm]	H2 [mm]	H1 [mm]	H2 [mm]
2 1/2" (65)	72.5	13.0	---	13.0	---	10.4	---
3" (80)	72.5	15.6	---	15.6	---	12.5	---
4" (100)	72.5	19.0	5.0	19.0	5	15.2	6
6" (150)	102.0	27.7	10.0	27.7	10	---	---
8" (200)	102.0	38.9	16.0	38.9	16	---	---
10" (250)	102.0	48.4	21.0	48.4	21	---	---
12" (300)	102.0	61.3	28.0	61.3	28	---	---
14" (350)	102.0	61.3	28.0	61.3	28	---	---
16" (400)	102.0	69.1	31.5	---	---	---	---

Screw-on PVC, PP, PE
DN 100 to 400

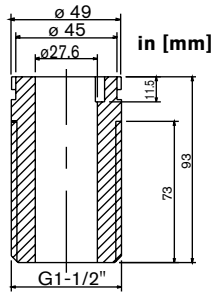

Note: long sensor version

Saddle- PVC

Body material: PVC, Seal material: BUNA

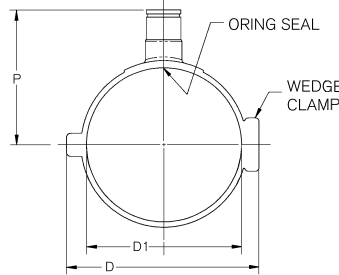

DIA.	D[mm]	P[mm]	D1[mm]
2 1/2" (65)	129	115.0	75.0
3" (80)	144	119.0	90.0
4" (100)	163	107.0	114.0
6" (150)	219	168.0	168.0
8" (200)	272	191.0	218.0

Note: short sensor version required up to 4". Long sensor version required 6"-8"

Saddle – carbon steel

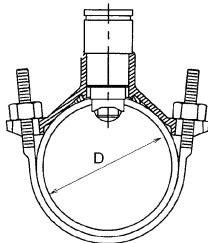

Pipe Size	D [in.]
2"	2.35 – 2.56
3"	2.97 – 3.54
4"	4.14 – 4.80
5"	4.74 – 5.63
6"	5.94 – 6.90
8"	7.69 – 9.05
10"	10.64 – 12.12
12"	10.64 – 12.12
14"	14.73 – 15.65

Note: Vertical mounting is recommended for best overall performance. Mount at a maximum of 45° when air bubbles are present. Do not mount on the bottom of the pipe when sediments are present.

Weldolet – carbon steel

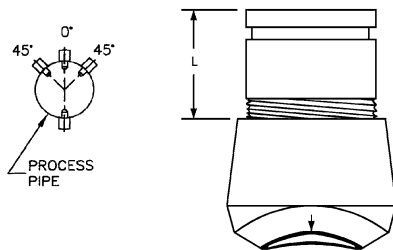

Pipe Size [in.]	L [in.]
2"	2.61
2 1/2"	2.53
3"	2.47
4"	2.38
6"	2.19
8"	2.00
10"	1.80
12"	1.62
14"	1.50

Note: Vertical mounting is recommended for best overall performance. Mount at a maximum of 45° when air bubbles are present. Do not mount on the bottom of the pipe when sediments are present.

Ordering chart for insertion fitting S020

Brass – T-fitting

Port connection	Specification		Item no. / Orifice						
	Seal	Standards	1/2" (DN 15)	3/4" (DN 20)	1" (DN 25)	1 1/4" (DN 32)	1 1/2" (DN 40)	2" (DN 50)	2 1/2" (DN 65)
Internal thread	FKM	NPT	428 718	428 719	428 720	428 721	428 722	428 723	---
		G	428 712	428 713	428 714	428 715	428 716	428 717	---
		Rc (ISO7)	428 724	428 725	428 726	428 727	428 728	428 729	---
External thread	FKM	G	428 730	428 731	428 732	428 733	428 734	428 735	---

Stainless steel – T-fitting

Port connection	Specification		Item no. / Orifice						
	Seal	Standards	1/2" (DN 15)	3/4" (DN 20)	1" (DN 25)	1 1/4" (DN 32)	1 1/2" (DN 40)	2" (DN 50)	2 1/2" (DN 65)
Internal thread	FKM	NPT	428 742	428 743	428 744	428 745	428 746	428 747	---
		G	428 736	428 737	428 738	428 739	428 740	428 741	---
		Rc (ISO7)	428 748	428 749	428 750	428 751	428 753	428 754	---
External thread	FKM	G	428 754	428 755	428 756	428 757	428 758	428 759	---
	EPDM	SMS 1145	---	---	443 317	---	443 318	443 319	---
Weld ends	FKM	EN ISO 1127/ISO 4200	---	428 760	428 761	428 762	428 763	428 764	428 765
	EPDM	BS4825 / ASME BPE	---	443 734	443 735	443 736	443 942	443 943	443 944
		SMS 3008	---	---	443 309	---	443 310	443 311	443 312
Tri-Clamp®	FKM	EN ISO 1127/ISO 4200	---	428 766	428 767	428 768	428 769	428 770	428 771
	EPDM	BS4825/ASME BPE	---	443 965	443 966	---	443 967	443 968	443 969
		SMS3017/ISO2852	---	---	443 313	---	443 314	443 315	443 316
		BS4825/ASME BPE*	---	443 970	443 971	---	443 972	443 973	443 974
Flange	FKM	SMS3017/ISO2852*	---	---	443 957	---	443 958	443 959	443 960
		ANSI B16-5-1988	428 778	428 779	428 780	428 781	428 782	428 783	---
		DIN 2633	428 772	428 773	428 774	428 775	428 776	428 777	---
		JIS 10K	431 053	431 054	431 055	431 056	431 057	431 058	---

* internal surface finish Ra = 0.8 µm

Stainless steel – welding tab with radius

Specification	2" (DN 50)	2 1/2" (DN 65)	3" (DN 80)	4" (DN 100)	5" (DN 125)	6" (DN 150)	8" (DN 200)	10" (DN 250)	12" (DN 300)	14" (DN 350)
Weld tabs	418 111	418 112	418 113	418 114	418 115	418 116	418 117	418 756	720 070	416 637

Carbon steel saddles – (requires long finger sensor)

Specification	2" (DN 50)	3" (DN 80)	4" (DN 100)	5" (DN 125)	6" (DN 150)	8" (DN 200)	10" (DN 250)	12" (DN 300)	14" (DN 350)
	US50B49	US50B32	US50B33	US50B34	US50B35	US50B36	US50B37	US50B38	TBD

Carbon steel weldolet – (requires long finger sensor)

Specification	2" (DN 50)	2 1/2" (DN 65)	3" (DN 80)	4" (DN 100)	5" (DN 125)	6" (DN 150)	8" (DN 200)	10" (DN 250)	12" (DN 300)
	US50B61	US50C34	US50C35	US50B27	US50B28	US50B29	US50B30	US50B31	US50C55

PVC – T-fitting

Port connection	Specification		Item no. / Orifice					
	Seal	Standards	1/2" (DN 15)	3/4" (DN 20)	1" (DN 25)	1 1/4" (DN 32)	1 1/2" (DN 40)	2" (DN 50)
True union - solvent spigot	FKM	ASTM	428 682	428 683	428 684	428 685	428 686	428 687
		ISO	428 670	428 671	428 672	428 673	428 674	428 675
		JIS	429 078	429 079	429 080	429 081	429 082	429 083
Solvent ends	FKM	ISO	428 676	428 677	428 678	428 679	428 680	428 681
For Analysis: True union- solvent spigot	FKM	ISO	430 837	430 838	460 839	428 673	428 674	4428 675

Ordering chart for insertion fitting S020

PVC saddle – (long finger required for 6" & 8" saddle)

Specification	Item no. / Orifice				
	2" (DN 50)	3" (DN 80)	4" (DN 100)	6" (DN 150)	8" (DN 200)
	413 469 W	413 470 T	US50B20	US50B17	US50B42

PVC – Screw-on fitting

Specification	Item no. / Orifice									
	2 1/2" (DN 65)	3" (DN 80)	4" (DN 100)	5" (DN 125)	6" (DN 150)	8" (DN 200)	10" (DN 250)	12" (DN 300)	14" (DN 350)	16" (DN 400)
	---	---	418 170	418 170	418 170	418 170	418 170	418 170	418 170	418 170

PP – T-fitting

Port connection	Specification			Item no. / Orifice					
	Seal	Standards		9/16" (DN 6)	3/4" (DN 20)	1" (DN 25)	1 1/4" (DN 32)	1 1/2" (DN 40)	2" (DN 50)
True union - solvent spigot	FKM	ISO		428 688	428 689	428 690	428 691	428 692	428 693
Solvent ends	FKM	ISO		428 694	428 695	428 696	428 697	428 698	428 699
For Analysis: True union- solvent spigot	FKM	ISO		430 840	430 841	460 842	428 691	428 692	428 693

PP – Fusion spigot or Screw-on fitting

Specification	Item no. / Orifice									
	2 1/2" (DN 65)	3" (DN 80)	4" (DN 100)	5" (DN 125)	6" (DN 150)	8" (DN 200)	10" (DN 250)	12" (DN 300)	14" (DN 350)	16" (DN 400)
Fusion spigot	418 650	418 651	418 652	---	418 653	418 654	418 655	418 656	418 657	---
Screw-on	---	---	436 488	436 488	436 488	436 488	436 488	436 488	436 488	436 488

PVDF – T-fitting

Port connection	Specification			Item no. / Orifice					
	Seal	Standards		3/4" (DN 20)	1" (DN 25)	1 1/4" (DN 32)	1 1/2" (DN 40)	2" (DN 50)	2 1/2" (DN 65)
True union - solvent spigot	FKM	ISO		428 700	428 701	428 702	428 703	428 704	428 705
Solvent ends	FKM	ISO		428 706	428 707	428 708	428 709	428 710	428 711
For Analysis: True union- solvent spigot	FKM	ISO		430 843	430 844	460 845	428 703	428 704	428 705

PVDF – Fusion spigot or Screw-on fitting

Specification	Item no. / Orifice									
	2 1/2" (DN 65)	3" (DN 80)	4" (DN 100)	5" (DN 125)	6" (DN 150)	8" (DN 200)	10" (DN 250)	12" (DN 300)	14" (DN 350)	16" (DN 400)
Fusion spigot	418 658	418 659	418 660	---	---	---	---	---	---	---

PE – Fusion spigot or Screw-on fitting

Specification	Item no. / Orifice									
	2 1/2" (DN 65)	3" (DN 80)	4" (DN 100)	5" (DN 125)	6" (DN 150)	8" (DN 200)	10" (DN 250)	12" (DN 300)	14" (DN 350)	16" (DN 400)
Fusion spigot	418 642	418 643	418 644	---	418 645	418 646	418 647	418 648	418 649	418 598
Screw-on	---	---	436 489	436 489	436 489	436 489	436 489	436 489	436 489	436 489

