

Sensor TA10 ... ZG2b with integrated transducer U10a

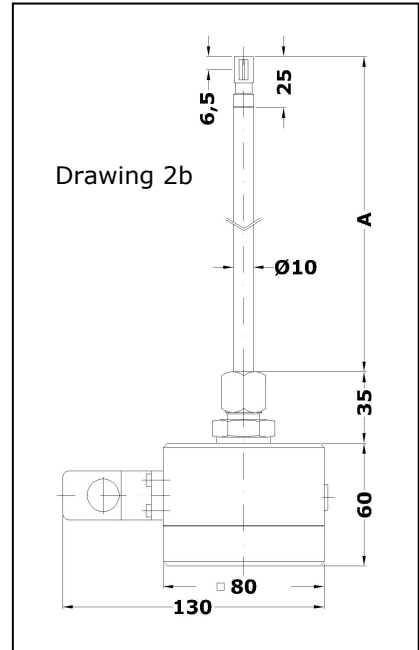

TA10 ... ZG2b (Meas. A Page 2)

Measurable variable

- standard velocity N_v , standard volume flow NV/t , mass flow proportional
- norm:
temperature $t_n = +21\text{ °C}$,
pressure $p_n = 1014\text{ hPa}$

Functional principle

- measurement of flow according to heat transfer method
- temperature dependence of measurement compensated by complete temperature operating range

Design

Probe with integrated transducer

Gases

- pure gases, gas mixtures: air, nitrogen, methane, natural gas, argon, carbon dioxide, helium, sulphur hexafluoride, biogas ...
- a calibration with a multitude of gases or gas mixtures can be carried out to achieve the slightest measuring uncertainty

Advantages

- high measuring dynamics N_v (up to 1 : 1000)
- measuring range from 0.2 m/s
- low measuring uncertainty, even at lowest flow velocities
- direct air/gas mass flow-proportional measuring. Additional measuring of pressure and temperature not necessary
- sensor has no moving parts
- stainless steel sensor housing
- greater working temperature and pressure ranges
- low installation costs
- low pressure drop due to small dimensions
- long life
- sterilisable (sensor material-resistance allowing)
- optional, double-spaced LCD: volume flow / counter
- parameterization and optimal integration with PC software

Range and examples of application

- measuring
 - air velocity
 - compressed air and gas consumption, leakage
 - laminar flows in clean rooms or machines
 - in outgoing air, burner supply air and draughts
 - in climatic applications
 - in air in rough vacuum range with pressures greater than 200 hPa abs.

Particles, condensation, humidity in the gas

- charges in the gas caused by particles such as dust and fibres do not affect the measurement, as long as abrasion and agglomeration do not occur on the sensor
- deviations in values as a result of variable air humidity in normal atmospheric conditions are covered by the measuring uncertainty specifications

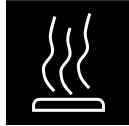

Model designation (example)

TA10	-165	G	E	140	p16	ZG2b
(1)	(2)	(3)	(4)	(5)	(6)	(7)

Basic types

Type	Article No.
TA10- 165 GE 140 / p16 ZG2b	b013/050
TA10- 265 GE 140 / p16 ZG2b	b013/051
TA10- 365 GE 140 / p16 ZG2b	b013/052
TA10- 665 GE 140 / p16 ZG2b	b013/053
TA10- 965 GE 140 / p16 ZG2b	b013/054

(1) Sensor type / Probe diameter

Thermal flow sensor
Probe diameter 10 mm

(2) Probe length measurement A

Standard length (see Basic types)	165, 265, 365, 665, 965 mm
Fix probe length based on	insertion depth in measurement cross section, muff length, length of ball valve and probe guide piece (see Accessories)

(3) Gases

Air, clean gases, gas mixtures with consistent ratio of mixture

(4) Materials in contact with the medium

Stainless steel 1.4571, 1.4305, 1.4404, glass, epoxy resin

Measuring ranges air/nitrogen

	Article No.
0.2 ... 60 m/s	v_ta10_2b_60
0.2 ... 120 m/s	v_ta10_2b_120
0,2 ... 150 m/s	v_ta10_2b_150
0.2 ... 180 m/s	v_ta10_2b_180
0.2 ... 200 m/s	v_ta10_2b_200

Measuring uncertainty / Time constant

Measuring uncertainty for flow velocities Nv with 1014 hPa and +21 °C	
less than/equal to 40 m/s	: 2 % of test value + 0.02 m/s
greater than 40 m/s	: 2.5 % of test value
time constant	: in seconds

Depositing a characteristic for application in other gases

based on	Article No.
calibration in air and conversion air characteristic for another gas, up to 60 m/s, measuring uncertainty totalling 5 ... 7 % of test value (on request)	ta_transfo
real gas calibration for achieving slightest measuring uncertainties	(on request)

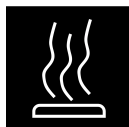

Examples for measurable volume flows

meas. tube inside diameter Di [mm]	profile factor PF* [-]	smallest measur- able value [Nm ³ /h]	measuring range terminal values[Nm ³ /h] sensor measuring range				
			'60 m/s'	'120 m/s'	'150 m/s'	'180 m/s'	'200 m/s'
25	0.725	0.26	77	154	192	231	256
40	0.810	0.73	220	440	550	660	730
50	0.840	1.2	356	713	890	1070	1180
60	0.840	1.7	513	1030	1280	1540	1710
80	0.840	3.0	912	1820	2280	2740	3040
100	0.840	4.8	1425	2850	3560	4280	4750
120	0.840	6.8	2050	4100	5130	6160	6840
150	0.840	11	3210	6410	8020	9620	10600
200	0.840	19	5700	11400	10700	17100	19000
300	0.840	43	12820	25650	32060	38480	42750
400	0.840	76	22800	45600	57000	68400	76000
500	0.840	120	35600	71200	89100	106900	118800
1000	0.840	480	142500	285000	356300	427600	475000

Standard volume flow measuring range specifications with centric positioning of the sensor, irrotational afflux and amply-dimensioned input and output section (see Instruction Manual).

* The profile factor PF describes the ratio of average flow velocity in the measurement cross section and the flow velocity measured from the sensor. The afore-mentioned operating conditions apply.

(5) Permissible temperature

medium	-10 ... +140 °C
ambient	-25 ... +50 °C
	-5 ... +50 °C option 'LCD'

(6) Maximum working pressure

max. 16 bar / 1.6 MPa above atmospheric
greater than 16 bar / 1.6 MPa on request

(7) Design

probe with connection housing; as drawing ZG2b (Page 1)

Ingress protection / Fitting attitude

sensor IP68
any attitude

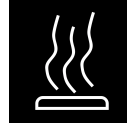
Connection housing AS80

measurements	80 / 80 / 60 mm (L / W / H)
connection	GO 070 with terminal screws
terminal connections	see Page 6
protection	IP65

Transducer U10a, integrated in sensor connection housing

analog output flow	4 ... 20 mA (linear), output every second, burden max. 400 Ohm
pulse output	quantity measurement, open collector / max. 30 V, 20 mA / duration 0.5 s, max. pulse frequency 1 Hz per volume unit NV
PC interface	RS232
connection	output signals electrically isolated from power supply appliance plug with GO 070 FAM fitted to connection housing, contact box GO 070 WF for terminal screw connection, for cables with outside diameter 4 ... 10 mm and cross section 0.14 ... 0.5 mm ²
power supply	24 V DC +/- 5 %
power consumption	less than 5 W, power cables electrically isolated from connection cables
housing	sensor connection housing AS80
EMC	EN 61 000-6-2:2001
setting parameter	analog output, time constant, profile factor, tube inside diameter, quantity pulse (rating adjustable), 'working pressure'

Setting parameter with PC software UCOM and programming adapter (see below) changeable

Options

	Description	Article No.
local LCD with quantity counter	illuminated, in housing cover, 2 x 16 digit, 3 mm high, temperature range -5 ... +50 °C, line 1 – instantaneous value (volume flow), line 2 – quantity counter (volumes)	a010/007
Protective system ATEX category 3G (zone 2)	Ex nA IIC T4	taex2

Accessories

	Description	Article No.
PC software UCOM	for configuring transducer U10a via RS232	a010/052
programming adapter GO 070 / RS232	for software UCOM, connection PC Sub-D 9-pin, plug to mains supply 230VAC/24VDC	a010/004
interface converter USB / RS232	connects PC with USB interface and Höntzsch programming adapter with RS232 interface, PC connection: USB plug type A programming adapter: sub-D 9-pin	a010/100



Accessories (continued)		
	Description	Article No.
calibration certificate Nv	min. 6 standard calibration values	klb
probe guide piece SFB 10 E-35 / G 1/2" ZG5 as in Drawing 5	unlimited and repeated positioning at low pressures above atmospheric (max. 3 bar) / subatmospheric, for connecting to screw socket or ball valve with inside thread G 1/2", threaded height 22 mm, working temperature range -20 ... +240 °C, installation length 35 mm, materials: stainless steel, VITON®, PTFE clamping bush	b004/503
probe guide piece SFB 10 E-60 / G 1/2" ZG6 with clamp clip for locking and anti-twist device, as in Drawing 6	unlimited and repeated positioning even at higher pressures above atmospheric / subatmospheric, clamping device for safeguarding fixing of probe, for connecting to screw socket or ball valve with inside thread G 1/2", working temperature range -20 ... +240 °C, installation length 55 mm, materials: stainless steel, VITON®, PTFE clamping bush	b004/600
probe guide piece SFB 10 E-60 / G 1/2" ZG7 with chain safety device and clamp clip for locking and anti-twist device, as in Drawing 7	unlimited and repeated positioning even at higher pressures above atmospheric / sub-atmospheric, clamping device for safeguarding fixing of probe and chain safety device, for connecting to screw socket or ball valve with inside thread G 1/2", working temperature range -20 ... +240 °C, installation length 55mm, materials: stainless steel, VITON®, PTFE clamping bush	b004/601

Drawing 5

Probe guide piece
SFB 10 E-35 / G 1/2" ZG5

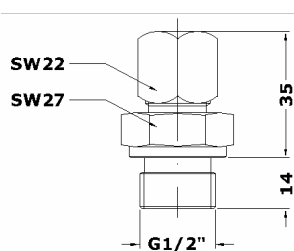

Drawing 6

Probe guide piece
SFB 10 E-60 / G 1/2" ZG6

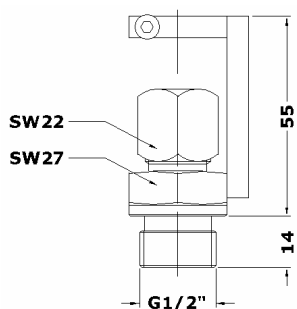

Drawing 7

Probe guide piece
SFB 10 E-60 / G 1/2" ZG7
with chain safety device

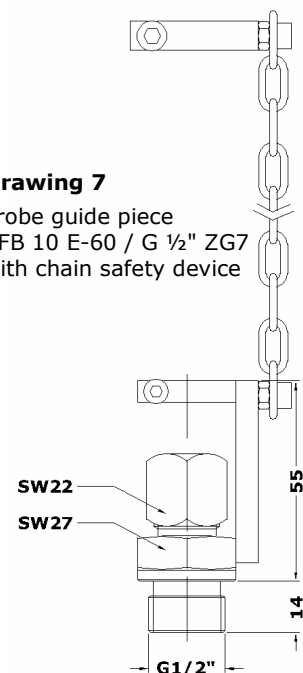

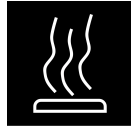

Accessories (continued)

	Description	Article No.
Ball valve	installation length 60 mm, through hole 15 mm, stainless steel 1.4408, seal PTFE, working temperature range max. +200 °C, working pressure 64 bar/6.4 MPa rel., connection thread G 1/2" inside (DIN/ISO 228)	b004/900



optional LCD in housing cover

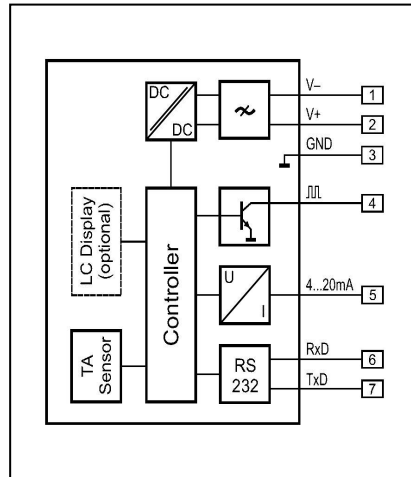

wiring diagram transducer U10a

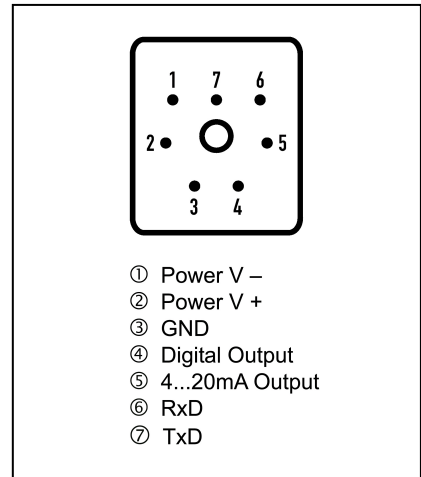

pin configuration plug GO 070

Höntzsch GmbH
Gottlieb-Daimler-Straße 37
D-71334 Waiblingen (Hegnach)
Telefon +49 7151 / 17 16-0
Telefax +49 7151 / 5 84 02
E-Mail info@hoentzsch.com
Internet www.hoentzsch.com

® : Registered trade mark
of DuPont

Subject to alteration

All prices net in EURO.
Delivery ex works Waiblingen plus
postage and packing and current
rate of VAT.

Valid from July 2005